

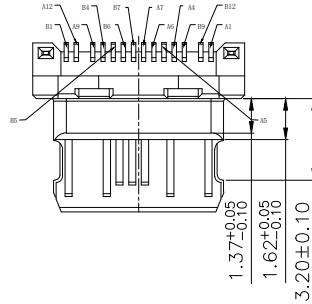

REV	DESCRIPTION	DATE	APPROVED
A	新版发行	2024.04.26	HHM

SPECIFICATION:

- ELECTRICAL:**
 - CURRENT RATING:5A;
 - CONTACT RESISTANCE:40mΩ Max;
 - DIELECTRIC WITHSTANDING VOLTAGE:100V AC;
 - INSULATION RESISTANCE:100 MΩ MIN;
- MECHANICAL;**
 - THIS PRODUCT DOES NOT HAVE A CASING, IT IS NON-STANDARD PRODUCT. THE INSERTION AND EXTRACTION FORCE CANNOT MEET THE REQUIREMENTS ASSOCIATION STANDARDS
 - MATING FORCE:5~20N;
 - UNMATING FORCE:5~20N;
 - DURABILITY:10000 CYCLES;
- MATERIAL:**
 - HOUSING&MOLDING:LCP BLACK UL94V-0;
 - TERMINAL:C7025 T=0.15mm;
 - MID PLATE:SUS304 T=0.15mm;
- PLATING SPECIFICATION:**
 - TERMINAL:CONTACT POINT GOLD PLATED 15u "MIN PIN WELDING AREA GOLD PLATED 1u" MIN.
- ELECTROPLATED PRODUCTS NEED TO UNDERGO TIN ADHESION TESTING: THE TIN ADHESION AREA SHOULD REACH OVER 95%.**
- SMT REFLOW SOLDERING (PEAK VALUE 260 ° C ± 5 ° C) SHALL BE FREE OF BLISTERING, GLUE MELTING AND POOR COLOR CHANGE (DEFORMATION WITHIN TOLERANCE)**
- OPERATING TEMPERATURE: -40° C~+85° C**

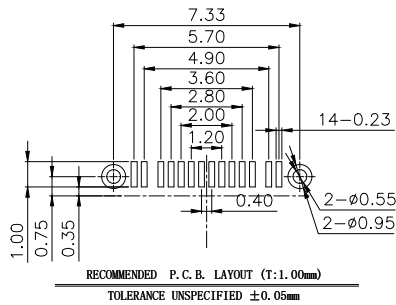
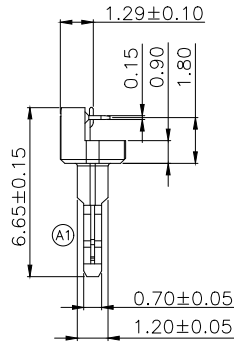
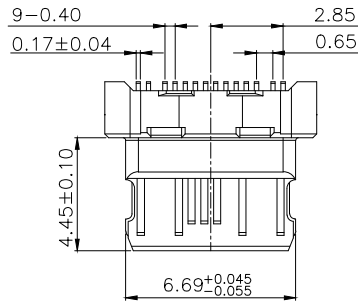
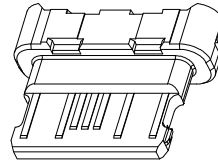
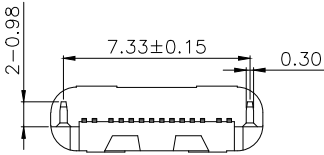

A1	GND	B12	GND
A4	VBUS	B9	VBUS
A5	CC1	B8	
A6	D+	B7	Dn2
A7	D-	B6	Dp2
A8		B5	CC2
A9	VBUS	B4	VBUS
A12	GND	B1	GND
PIN	SIGNAL NAME	PIN	SIGNAL NAME

CUSTOMER DRAWING			铭创科技(东莞)有限公司		
UNITS mm	SCALE 1:1	SHEET 1 OF 2	Mingchuang Technology (Dongguan) Co., Ltd.		
PROJECTION: 		DRAW: DAP	TITLE TYPE C母座14PIN 沉板1.6 后两脚插板SMT L=6.65 CH=0.00		
GENERAL TOLERANCE .000 ±0.15 .00 ±0.20 .0 ±0.25 .0 ±2° .00 ±1°		CHECK: HWT	MAT'L SEE TABLE	FINISH SEE TABLE	
		APPD: HHM	DWG. NO. A031408A	PART NO. _____	SIZE A4

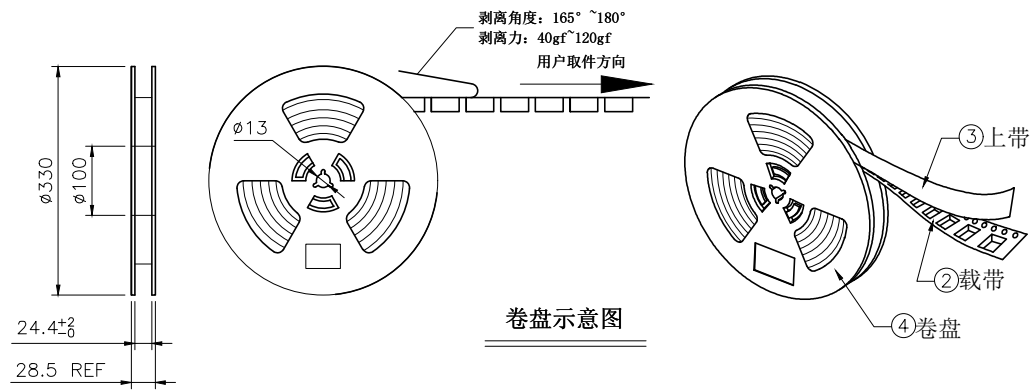
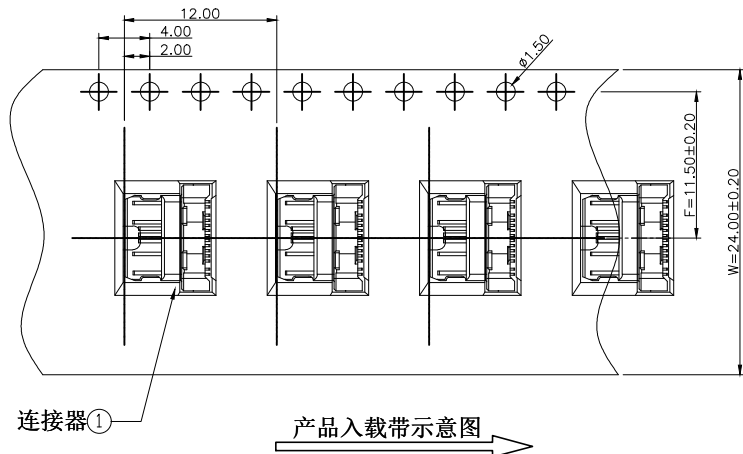

REV	DESCRIPTION	DATE	APPROVED
A	新版发行	2024.04.26	HHM

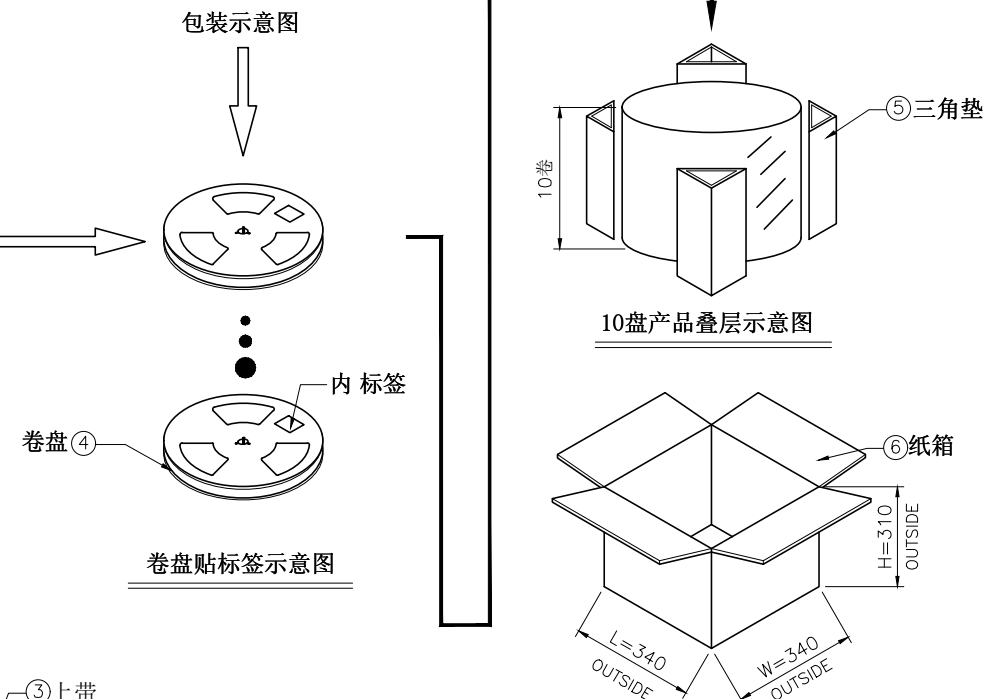

- 技术要求:
- 载带前面留15PCS空格, 后面留20PCS空格, 不装产品;
 - 每穴放置1PCS产品, 每卷装1500PCS产品, 放置方式如图所示;
 - 将包装好的产品;每盘必需贴上内标签;将贴好内标签的产品每10盘堆叠;
 - 在纸箱四角垫上4个三角垫, 然后把装好产品的卷盘放入纸箱中, 最后用胶带封箱; (如客户有要求, 请按客户要求包装出货)
 - 上带与载带的剥离力: 40gf~120gf, 跳动量在30gf内; (剥离角度: 165°~180°, 剥离速度: 250~300mm/min)
 - 产品符合RoHS环保标准要求.

06	纸箱	B-05-0011	340mm*340mm*310mm	1 PCS
05	三角垫	/	300mm*260mm*7mm	4 PCS
04	卷盘	/	D=330mm, d=100mm, H=28.5mm	10 PCS
03	上带	/	W=20.7mm, T=0.05mm	18000 mm
02	载带	B-03-0005	W=24mm, T=0.50mm, P=12.0mm	18000 mm
01	连接器	A031408A	14PIN, SMT	15000 PCS
序号	物料名称	物料编号	规格	描述

CUSTOMER DRAWING			铭创科技(东莞)有限公司		
UNITS mm	SCALE 1:1	SHEET 2 OF 2	Mingchuang Technology (Dongguan) Co., Ltd.		
PROJECTION: 	DRAW: DAP	TITLE TYPE C母座14PIN 沉板1.6 后两脚插板SMT L=6.65 CH=0.00			
GENERAL TOLERANCE .000 ±0.15 .00 ±0.20 .0 ±0.25 .0 ±2° .00 ±1°	CHECK: HWT	MAT'L SEE TABLE	FINISH SEE TABLE		
	APPD: HHM	DWG. NO. A031408A	PART NO. _____	SIZE A4	