

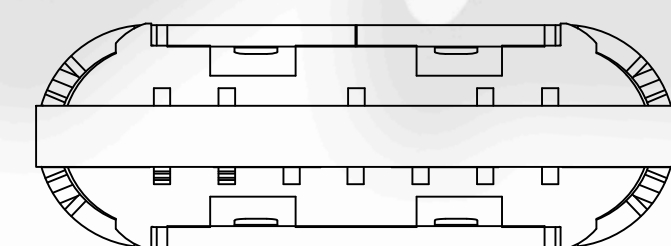

1	2	3	4	5	6
REV	DESCRIPTION			DATE	APPROVED

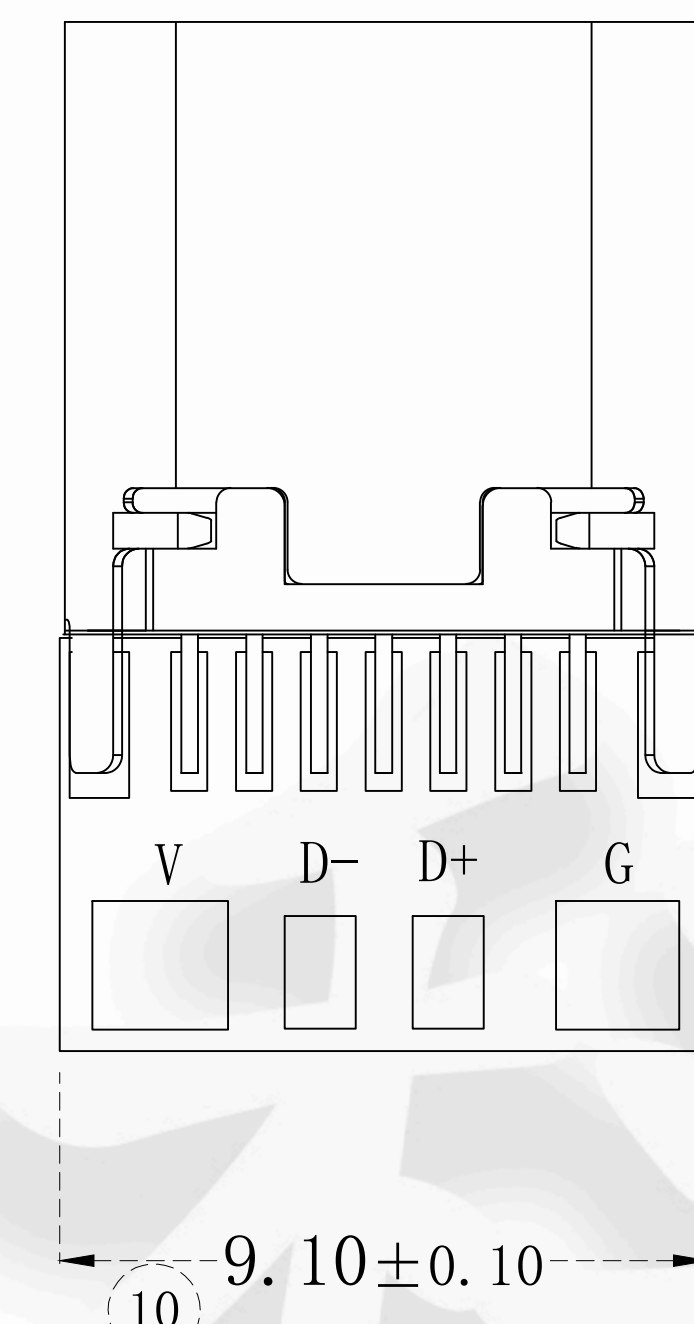
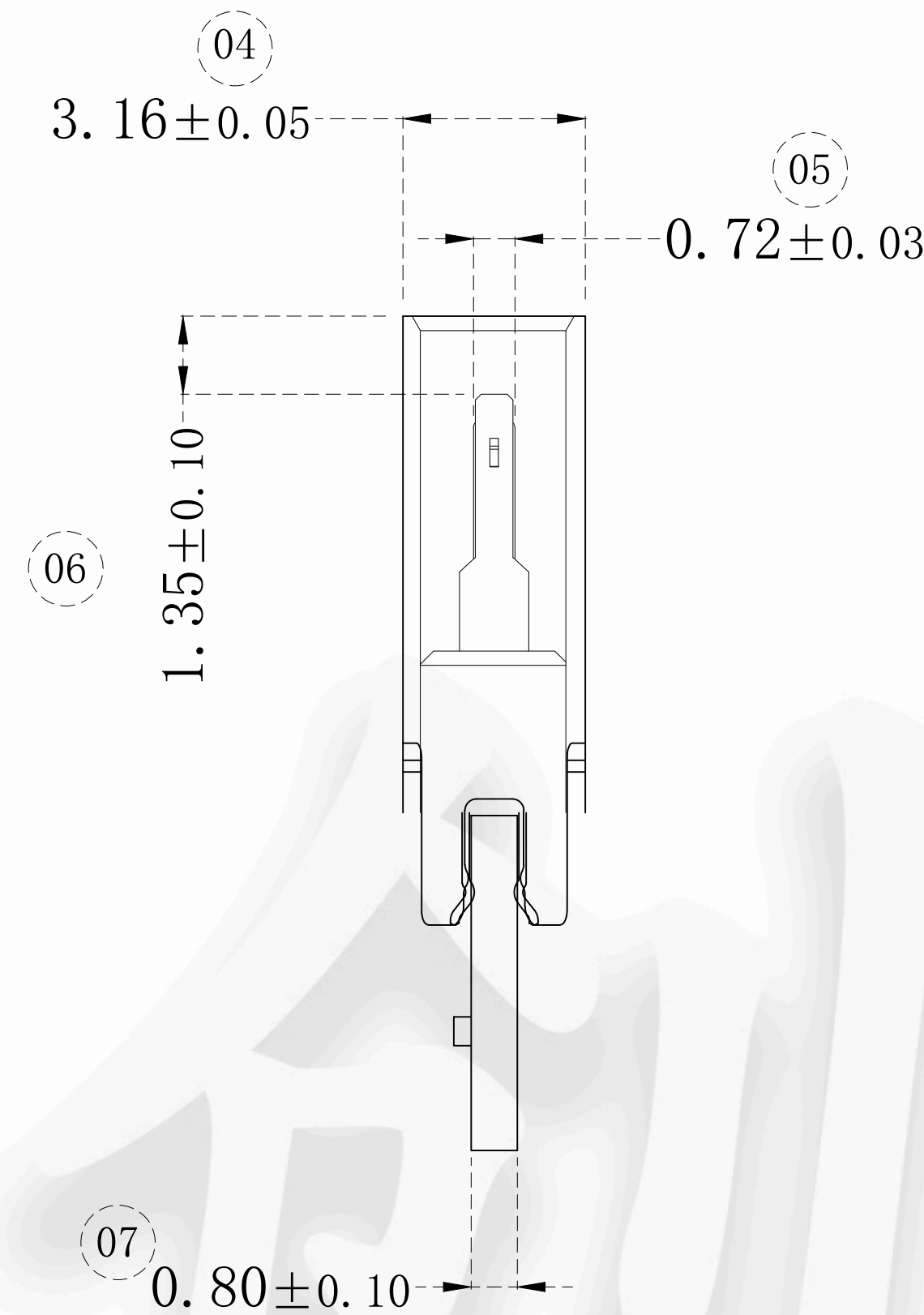
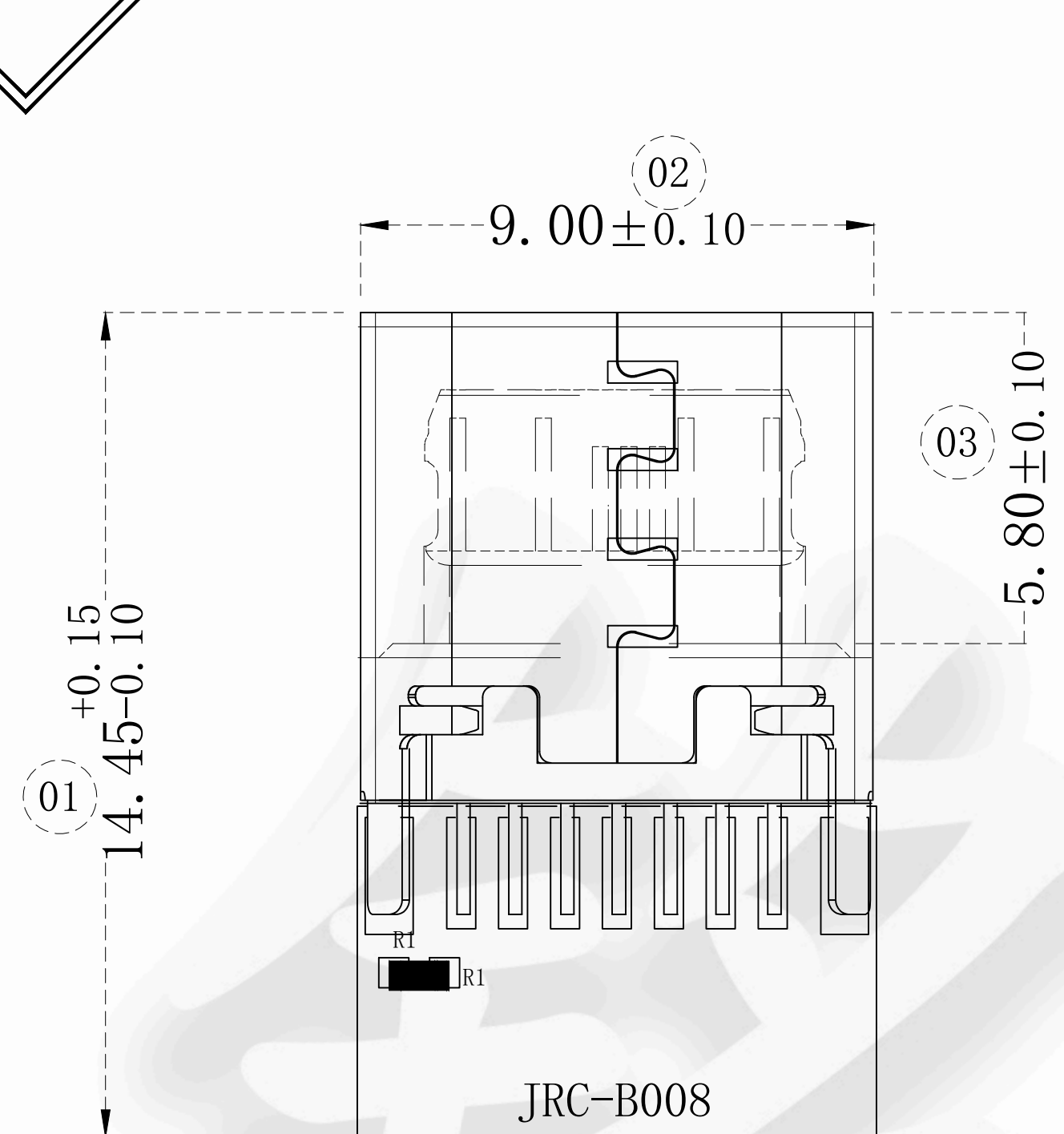

备注:

- 电气测试:
 - 1.1接触电阻: 30mΩ MAX, 寿命后变化±10mΩ
 - 1.2耐电压: 100V AC
 - 1.3绝缘电阻: 1000MΩ MIN
 - 1.4额定电流 3A
- 机械测试
 - 2.1耐久测试: 10000次;
 - 2.2插入力: 5~20N Max;
 - 2.3拔出力: 8~20N Min;
- 包装:
 - 3.1 PE袋包装, 最小包装量1000PCS
- 环境
 - 4.1工作温度: -25℃~+88℃

B06-042-XXXXX-XXXX/XXXX-P008B

01: 黑色	0: 素材	00: 无电镀	PCB板
02: 白色	A: 半金锡	01: G/F (06)	图号
03: 白透蓝	B: 全锡	02: 3U" (12H)	
04: 绿色	C: 亮镍	03: 5U" (24H)	
05: 微绿色	D: 可焊镍	04: 15U" (36H)	
06: 墨绿色	E: 全金	05: 30U" (48H)	
07: 莹绿色	F: 珍珠镍	06: 1U"	
08: 鲜绿色	G: 哑镍	07: 2U"	
		08: 100U"	

焊盘	G	D+	D-	V
针位	A1 A12 B1 B12	A6 B6	A7 B7	A4 A9 B4 B9
备注	R:G+B5(5.1KΩ)			

接点定义放大图(14P)

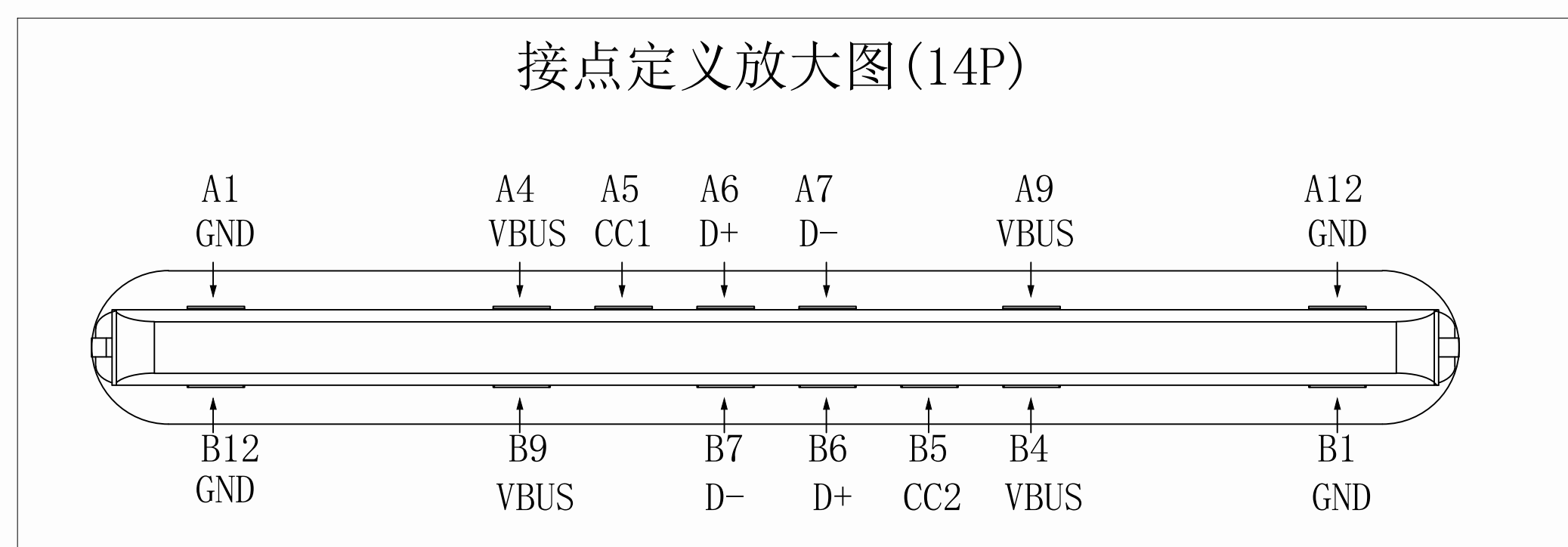

CUSTOMER DRAWING			铭创科技(东莞)有限公司		
UNITS mm	SCALE 1:1	SHEET	Mingchuang Technology (Dongguan) Co., Ltd		
PROJECTION: 		DRAW: DAP	TITLE TYPE C母座14PIN 夹板带板 四个焊盘 下拉5.1K电阻 201 LCP		
GENERAL TOLERANCE 0. ±0.35 0.0 ±0.25 0.00 ±0.15 0.° ±4° 0.0° ±3°		CHECK: HWT	MAT'L SEE TABLE		FINISH SEE TABLE
		APPD: HHM	DWG. NO. 0377.TCF.14YB.J72	PART NO.	SIZE A4